



259B2_6UP series

2W - Single/Dual Output DC-DC Converter - Isolated & Unregulated

DC-DC Converter 2 Watt

- ⊕ SIP9 Package
- ⊕ Ultra-High I/O Isolation
5000VAC with Reinforced
Insulation, rated for 300 Vrms
working voltage
- ⊕ CMTI 65 KV/μs at 1kV
Common mode voltage
- ⊕ Continuous short circuit
protection
- ⊕ Low coupling capacitance
Efficiency up to 86%
- ⊕ -40°C ~ 95°C operation
temperature range
- ⊕ Suitable for IGBT applications

Introducing our new 259B2_6UP series, designed to provide ultra-high I/O isolation of 5000VAC with reinforced insulation, ensuring safety and reliability for applications requiring a working voltage of up to 300 Vrms. This advanced package features an impressive Common Mode Transient Immunity (CMTI) of 65kV/μs at 1kV common mode voltage, offering superior performance in demanding environments. Engineered with continuous short circuit protection, the series guarantees robustness and durability in various operational conditions. It boasts low coupling capacitance, enhancing its efficiency, which can reach up to 86%. Additionally, it operates efficiently across a wide temperature range from -40°C to 95°C, making it suitable for diverse applications and challenging environments.



Common specifications	
Operating ambient temperature	-40 - +95 °C
Maximum case temperature	+115 °C
Thermal impedance	30 °C/W
Operating altitude	5000 m
Pollution degree	PD2
Storage humidity	95 % rel. H
Storage temperature	-55 - +125 °C
Cooling	Natural Convection / 30-65 LFM
Common mode transient immunity	1kV Common mode Voltage / 65 KV/μs
Leakage current	250VAC, 60Hz / 2.0 μA
Clearance / creepage	6 mm
Working voltage	300 Vrms
Overvoltage category	OV2
Clearance / creepage for x type	9 mm
Working voltage for x	300 Vrms
Overvoltage category for x type	OV3
Switching frequency	20 kHz
Mtbf (mil-hdbk-217f @25°C):	2.4 M hours
Safety approval	IEC / EN / UL 62368-1 - DK-131558-UL, E252573
Insulation grade	Reinforced Insulation
Environmental compliance	RoHS
Case material	Nonconductive black plastic (UL94V-0 rated)
Pin material	Tinned Copper
Potting material	Silicone (UL94V-0 rated)
Weight	4.3 g, typ.
Dimensions	0.77" x 0.39" x 0.49"

Isolation specifications					
Item	Test condition	Min	Typ	Max	Units
Isolation Voltage	Input-output, and rated for 60sec	5000			VAC
Isolation Resistance	Input-output	1000			MΩ
Isolation Capacitance	Input-output		10		pF

Example:

259B2_1205D6UP

2 = 2Watt; S9 = SIP9; B2 = Pinning; 12 = 12Vin; 05 = 5Vout; D = Dual Output;

6 = 6kVDC isolation; U = Unregulated Output; P = Short circuit protection

Output specifications					
Item	Test condition	Min	Typ	Max	Units
Output voltage accuracy		-3		+3	%
Line regulation	For 1% Vin Change	-1.2		+1.2	%
Load regulation	From 10% to 100% Load • 3.3V, 5V Output • 9V, 12V, 15V Output From 0% to 100% Load			15 10 35	% % %
Cross regulation	Asymmetrical Load 25% / 100% for Dual Output • 3.3V , 5V Output • Other Output	-8 -5		+8 +5	% %
Ripple & noise	• 20MHz bandwidth.			150	mVpk-pk
Temperature coefficient		-0.03		+0.03	%/°C
Maximum capacitive load	Minimum Vin and constant resistive load	See Table			

Input specifications					
Item	Test condition	Min	Typ	Max	Units
Voltage range	• 5V Input • 12V Input • 15V Input • 24V Input	4.5 10.8 13.5 21.6	5 12 15 24	5.5 13.2 16.5 26.4	VDC VDC VDC VDC
Input filter	Capacitor				
Input reflected ripple current*		20			mApk-pk
Start up time	Nominal Vin and constant resistive load	30			ms
Recommended input fuse (slow blow)	• 5V Input • 12V Input • 15V Input • 24V Input	1 0.4 0.4 0.2			A A A A
Input Surge Voltage (100 ms)	• 5V Input • 12V Input • 15V Input • 24V Input			7 15 18 28	VDC VDC VDC VDC
Soldering Temperature	1.5mm from case 10sec max.			260	°C

Note: *Measured with a simulated source inductance of 22μH and a source capacitor Cin (47μF, ESR<1.0Ω at 100kHz).

** These are stress ratings. Exposure of devices to any of these conditions may adversely affect long-term reliability.

2S9B2_6UP series

2W - Single/Dual Output DC-DC Converter - Isolated & Unregulated

Product Selection Guide

Approval	Part Number	Input voltage [V]	INPUT Current No-Load [mA, max.]	INPUT Current Full Load [mA, typ.]	Output voltage [V]	Output current [Min. load, mA]	Output current [Full load, mA]	Efficiency [%, Typ.]	Capacitive Load (μ F, max.)
	2S9B2_0503S6UP	4.5-5.5	50	501.26	3.3	0	600	79	3300
UL	2S9B2_0505S6UP	4.5-5.5	60	506.33	5	0	400	79	1200
	2S9B2_0509S6UP	4.5-5.5	60	493.33	9	0	222	81	1200
UL	2S9B2_0512S6UP	4.5-5.5	60	477.14	12	0	167	84	680
UL	2S9B2_0515S6UP	4.5-5.5	60	480.72	15	0	133	83	680
	2S9B2_1203S6UP	10.8-13.2	25	208.86	3.3	0	600	79	3300
UL	2S9B2_1205S6UP	10.8-13.2	30	200.80	5	0	400	83	1200
	2S9B2_1209S6UP	10.8-13.2	30	200.60	9	0	222	83	1200
UL	2S9B2_1212S6UP	10.8-13.2	30	200.30	12	0	167	83	680
UL	2S9B2_1215S6UP	10.8-13.2	30	200.30	15	0	133	83	680
	2S9B2_1503S6UP	13.5-16.5	25	167.09	3.3	0	600	79	3300
	2S9B2_1505S6UP	13.5-16.5	30	162.60	5	0	400	82	1200
	2S9B2_1509S6UP	13.5-16.5	30	162.44	9	0	222	83	1200
	2S9B2_1512S6UP	13.5-16.5	30	159.04	12	0	167	84	680
	2S9B2_1515S6UP	13.5-16.5	30	160.24	15	0	133	83	680
	2S9B2_2403S6UP	21.6-26.4	20	107.14	3.3	0	600	77	3300
UL	2S9B2_2405S6UP	21.6-26.4	20	101.62	5	0	400	82	1200
	2S9B2_2409S6UP	21.6-26.4	20	100.30	9	0	222	83	1200
UL	2S9B2_2412S6UP	21.6-26.4	20	99.40	12	0	167	84	680
UL	2S9B2_2415S6UP	21.6-26.4	20	100.15	15	0	133	83	680

Approval	Part Number	Input voltage [V]	INPUT Current No-Load [mA, max.]	INPUT Current Full Load [mA, typ.]	Output voltage [V]	Output current [Min. load, mA]	Output current [Full load, mA]	Efficiency [%, Typ.]	Capacitive Load (μ F, max.)
	2S9B2_0503D6UP	4.5-5.5	50	493.77	\pm 3.3	0	\pm 303	81	\pm 1500
UL	2S9B2_0505D6UP	4.5-5.5	60	493.82	\pm 5	0	\pm 200	81	\pm 470
	2S9B2_0509D6UP	4.5-5.5	60	481.44	\pm 9	0	\pm 111	83	\pm 470
UL	2S9B2_0512D6UP	4.5-5.5	60	480.00	\pm 12	0	\pm 83	83	\pm 330
UL	2S9B2_0515D6UP	4.5-5.5	60	490.24	\pm 15	0	\pm 67	82	\pm 330
UL	2S9B2_051509D6UP	4.5-5.5	60	495.64	+15 / -9	0	+67 / -111	83	\pm 330
	2S9B2_1203D6UP	10.8-13.2	25	203.23	\pm 3.3	0	\pm 303	82	\pm 1500
UL	2S9B2_1205D6UP	10.8-13.2	30	198.41	\pm 5	0	\pm 200	84	\pm 470
	2S9B2_1209D6UP	10.8-13.2	30	200.60	\pm 9	0	\pm 111	83	\pm 470
UL	2S9B2_1212D6UP	10.8-13.2	30	197.62	\pm 12	0	\pm 83	84	\pm 330
UL	2S9B2_1215D6UP	10.8-13.2	30	197.06	\pm 15	0	\pm 67	85	\pm 330
UL	2S9B2_121509D6UP	10.8-13.2	30	196.03	+15 / -9	0	+67 / -111	85	\pm 330
	2S9B2_1503D6UP	13.5-16.5	25	164.59	\pm 3.3	0	\pm 303	81	\pm 1500
	2S9B2_1505D6UP	13.5-16.5	30	160.64	\pm 5	0	\pm 200	83	\pm 470
	2S9B2_1509D6UP	13.5-16.5	30	158.57	\pm 9	0	\pm 111	84	\pm 470
	2S9B2_1512D6UP	13.5-16.5	30	154.41	\pm 12	0	\pm 83	86	\pm 330
	2S9B2_1515D6UP	13.5-16.5	30	155.81	\pm 15	0	\pm 67	86	\pm 330
	2S9B2_151509D6UP	13.5-16.5	30	158.69	+15 / -9	0	+67 / -111	84	\pm 330
	2S9B2_2403D6UP	21.6-26.4	20	104.15	\pm 3.3	0	\pm 303	80	\pm 1500
UL	2S9B2_2405D6UP	21.6-26.4	20	99.20	\pm 5	0	\pm 200	84	\pm 470
	2S9B2_2409D6UP	21.6-26.4	20	99.10	\pm 9	0	\pm 111	84	\pm 470
UL	2S9B2_2412D6UP	21.6-26.4	20	97.64	\pm 12	0	\pm 83	85	\pm 330
UL	2S9B2_2415D6UP	21.6-26.4	20	98.53	\pm 15	0	\pm 67	85	\pm 330
UL	2S9B2_241509D6UP	21.6-26.4	25	100.37	+15 / -9	0	+67 / -111	83	\pm 330

2S9B2_6UP series

2W - Single/Dual Output DC-DC Converter - Isolated & Unregulated

EMC specifications (EN50155)

Conducted Emissions	EN55032	with external components	Perf. Criteria B
Radiated Emissions	EN55032		Perf. Criteria B
ESD	IEC 61000-4-2	Air $\pm 15\text{kV}$ / Indirect: $\pm 6\text{kV}$	Perf. Criteria A
RS	IEC 61000-4-3	10V/m	Perf. Criteria A
EFT	IEC 61000-4-4	$\pm 2\text{kV}$ with external components	Perf. Criteria A
Surge	IEC 61000-4-5	$\pm 2\text{kV}$ with external components	Perf. Criteria A
CS	IEC 61000-4-6	10Vrms	Perf. Criteria A
PFMF	IEC 61000-4-8	100A/m	Perf. Criteria A

Typical characteristics

Temperature derating graph

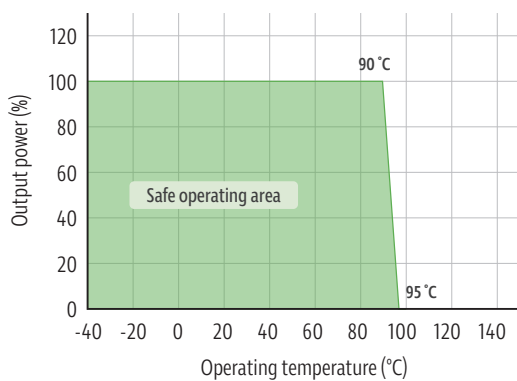

Output regulation curve

3.3 - 5V output

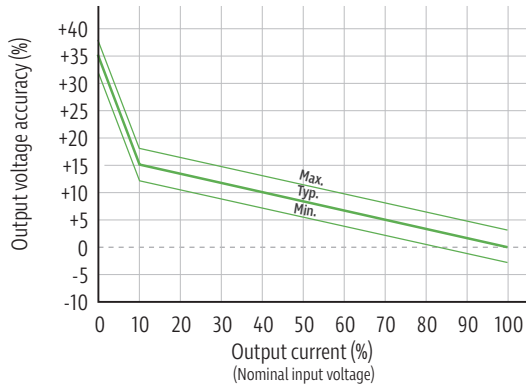

Output regulation curve

9 - 12 - 15V output

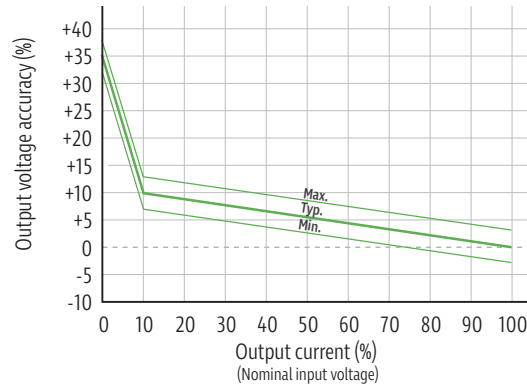

Input reflected ripple current test step

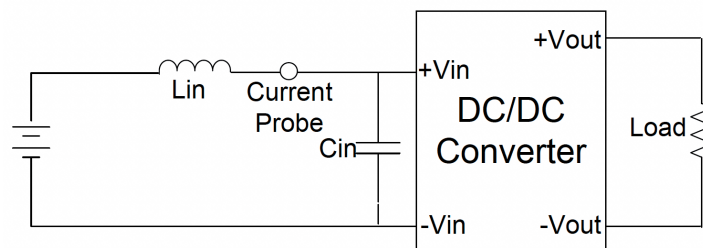

Input reflected ripple current is measured with a source inductor L_{in} (22 μH) and a source capacitor C_{in} (47 μF , ESR<1.0 Ω at 100kHz) at nominal input and full load.

2S9B2_6UP series

2W - Single/Dual Output DC-DC Converter - Isolated & Unregulated

EMC filter

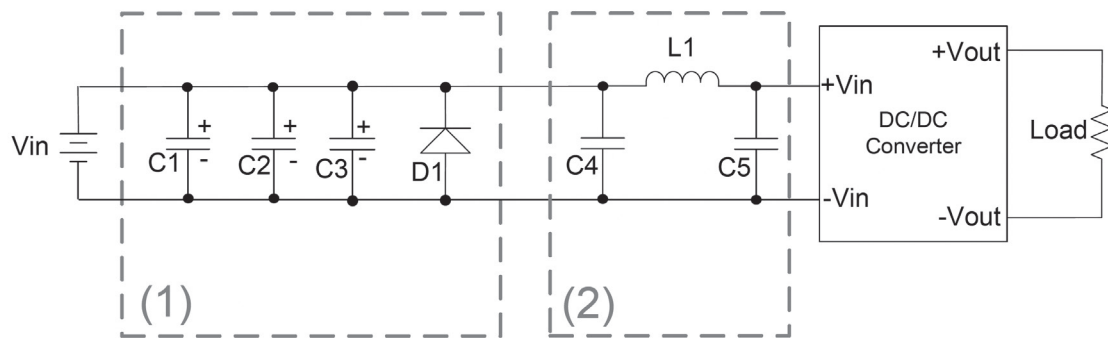

Vin	C1, C2	C3	D1	C4	L1	C5
5V	NIPPON Chemi-con KY Series 680μF, 100V	NIPPON Chemi-con KY Series 680μF, 100V	SMDJ8.0A	MLCC 4.7μF, 50V	6.8μH	DNP
12V		DNP	SMDJ16.0A	MLCC 10μF, 50V	6.8μH	MLCC 4.7μF, 50V
15V		DNP	SMDJ18.0A	MLCC 10μF, 50V	6.8μH	MLCC 4.7μF, 50V
24V		DNP	SMDJ28.0A	MLCC 10μF, 50V	6.8μH	MLCC 4.7μF, 50V

Mechanical dimensions

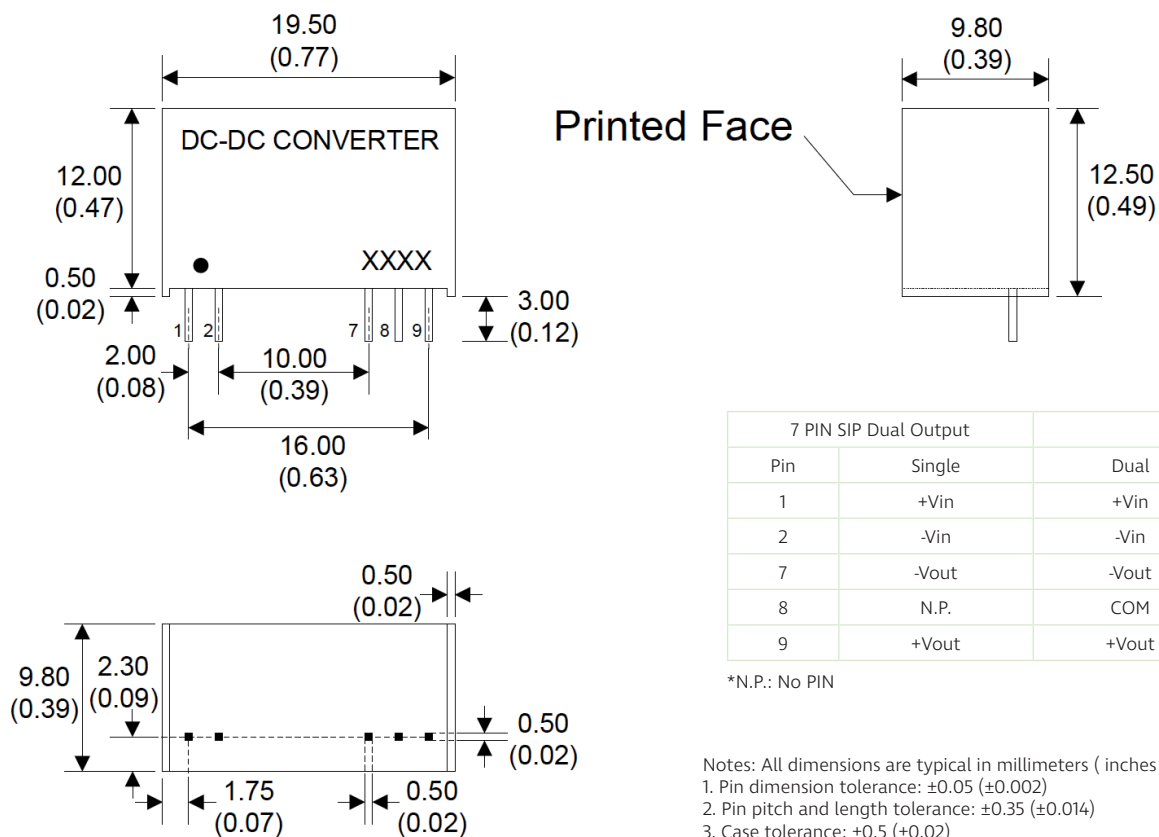

7 PIN SIP Dual Output		
Pin	Single	Dual
1	+Vin	+Vin
2	-Vin	-Vin
7	-Vout	-Vout
8	N.P.	COM
9	+Vout	+Vout

*N.P.: No PIN

Notes: All dimensions are typical in millimeters (inches).

1. Pin dimension tolerance: ± 0.05 (± 0.002)
2. Pin pitch and length tolerance: ± 0.35 (± 0.014)
3. Case tolerance: ± 0.5 (± 0.02)
4. Pin to Case tolerance: ± 0.5 (± 0.02)

2S9B2_6UP series

2W - Single/Dual Output DC-DC Converter - Isolated & Unregulated

Recommended footprint details

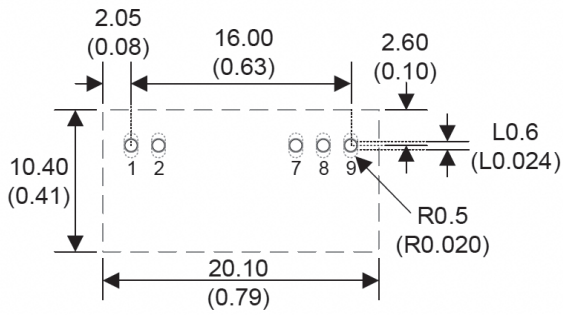

Notes: 1. All dimensions are typical in mm (inches).

Through hole 1 ~ 9: $\varnothing 0.90$ (0.035)

Top view pad 1 ~ 9: $\varnothing 1.00$ (0.039)

Bottom view pad 1 ~ 9: Groove R0.50 (0.020) L0.80 (0.031)

2. There should be at least 9mm distance between primary and secondary circuit.